

INSTRUCTION MANUAL

INSULATION TESTER

MODEL 869-100H

KIKUSUI ELECTRONICS CORPORATION

0
/

814619

TABLE OF CONTENTS

	PAGE
1. GENERAL	1
2. SPECIFICATIONS	2
3. OPERATION METHOD	7
3.1 Explanation of Front Panel	7
3.2 Explanation of Rear Panel	10
3.3 Precautions in Use	11
3.4 Test Procedure and Instrument Operation	13
4. CALIBRATION	19
5. OPTIONS	21
5.1 Model 929-100M Standard Resistor for Calibration	21
5.2 Model 913A Remote Control Box	22

814620

1. GENERAL

This instrument is an insulation resistance tester with two measuring ranges of 500V/1000M Ω and 1000V/2000M Ω .

The instrument is incorporated with a GO-NOGO judgement function and can be used very efficiently for test and measurement in a production line.

The indicating meter has two mutually independent pointers--one for the measured insulation resistance and the other the GO-NOGO reference value. The GO-NOGO reference value can be easily set. Comparison of the measured value with the GO-NOGO reference value is done rapidly with an electronic circuit, greatly improving the test work efficiency.

The instrument provides two types of output modes to suit different types of tasks. One output mode is such that, when the NG judgement is done in the GO-NOGO test, the output is immediately cut off and an NG alarm signal is generated. The other mode is such that, even when the NG judgement is done, the output is not cut off and the meter remains indicating the measured value. As you disconnect the tested object, the NG alarm is automatically reset and the test can be done continuedly.

2. SPECIFICATIONS

Rated measuring voltage:

500 V DC/1000 V DC (2 ranges), negative polarity

Effective measuring ranges:

500 V range: 1 M Ω ~ 1000 M Ω

1000 V range: 2 M Ω ~ 2000 M Ω

Scale center reading:

500 V range: approx. 20 M Ω

1000 V range: approx. 50 M Ω

Accuracy:

* 1st effective measuring range: $\pm 5\%$ of reading

* 2nd effective measuring range: $\pm 10\%$ of reading

(at 25°C \pm 10°C (77°F \pm 18°F), 20% to 90% RH)

(*: The 1st effective measuring range is 1/2 ~ 1/1000 of the maximum value of measuring range. The remaining range is the 2nd measuring range.)

Measuring terminal voltage:

When output terminals are open: +5%, -0% of rated voltage

At scale center: 95% or over of rated voltage

Indicating meter:

2-pointer type, with mirror, JIS Class 1.5

(2 pointers: One black pointer for measured value indication and the other red pointer for GO-NOGO reference value setting)

Scale length: 1000 V range approx. 97 mm

500 V range approx. 85 mm

GO-NOGO judgement:

Reference value setting range:

Any point within the effective measuring range

Accuracy of judgement:

1st effective measuring range: $\pm 15\%$ of set value

2nd effective measuring range: $\pm 20\%$ of set value

Result of judgement:

When measured value is lower than reference value,
NG alarm is generated.

- o NG lamp
- o NG buzzer (Loudness is adjustable with knob on rear panel.)
- o NG contact output ("make" when NG; 100 V AC, 1 A)

Output mode selection:

NORMAL: When NG is detected, the output is instantaneously cut off.

CONTINUE: Measurement can be done continuously.
(When NG is detected, NG alarm is generated.
As you disconnected the tested object, NG alarm is automatically reset.)

Test method:

- o Measurement can be done by selecting the required range and output mode, setting the reference value, and depressing the TEST button.
- o If you depress the RESET (OUTPUT OFF) button, the output is cut off and the NG alarm is reset.

814624

Power requirements:

Voltage range: 100 V $\pm 10\%$

Frequency: 50 ~ 60 Hz

Power consumption:

1000 V range: approx. 10 VA with output terminals open

1000 V range: approx. 20 VA with output terminals shorted

Insulation resistance: 50 M Ω or over between AC input line
and chassis, with 1000 V DC

Ambient temperature and humidity:

0°C ~ 40°C (32°F ~ 104°F), 20% ~ 90% RH

Dimensions and weight:

Dimensions: 200 W x 140 H x 270 D mm

(7.87W x 5.51H x 10.63D in.)

(Maximum dimensions): 205 W x 165 H x 315 D mm

(8.07W x 6.50H x 12.40D in.)

Weight: Approx. 3.7 kg (8.2 lbs.)

Accessories:

High voltage test leads 1 set

(HTL-1.5I, approx. 1.5 m (4.9 ft.))

Instruction manual 1 copy

814625

Options:

Model 913A Remote Control Box

Used being connected to DIN connector on rear panel.
TEST and RESET (OUTPUT OFF) can be remote-controlled.

Model 929-100M Standard Resistor for Calibration

100 M Ω standard resistor used for calibration at
approximately scale center.

(Note): Since this instrument is an AC line operation type, errors
may be introduced if the measured object is connected to the
AC line or to an earth ground.

3. OPERATION METHOD

3.1 Explanation of Front Panel

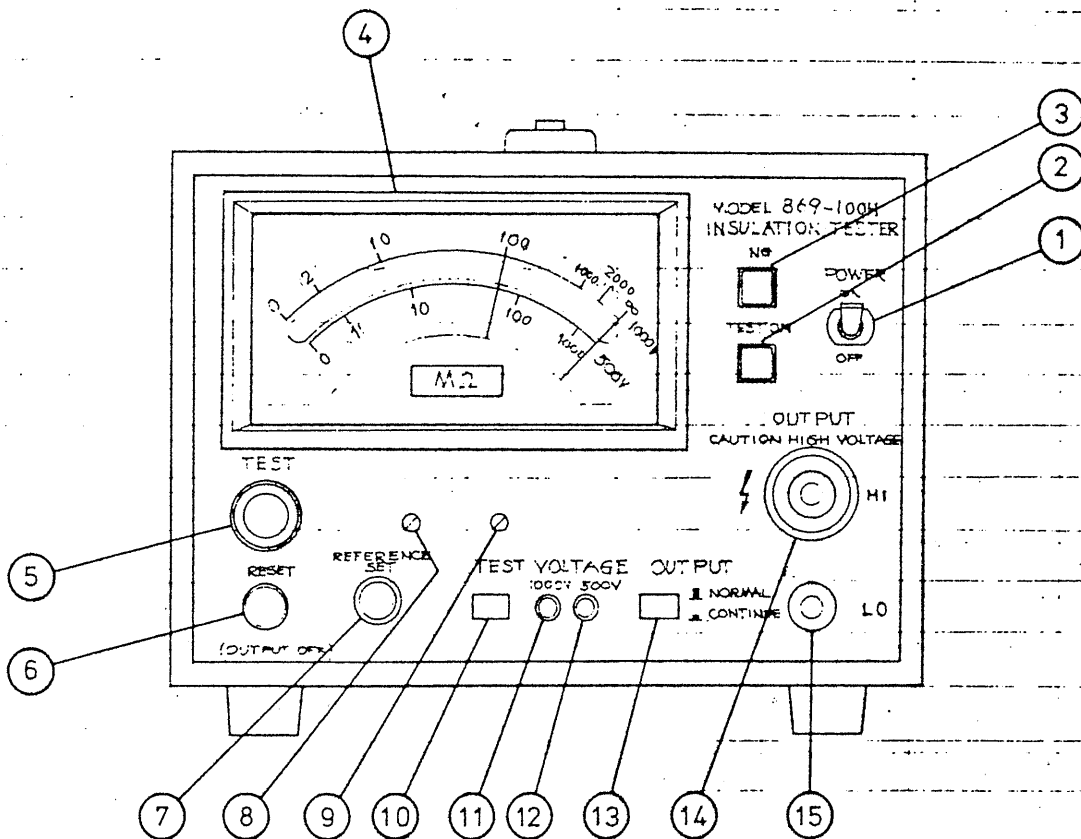

Figure 3.1

- ① POWER: Instrument main power switch. The upper position is for ON.
- ② TEST ON: This red lamp indicates that the test voltage is being fed to ⑭ OUTPUT terminals.
- ③ NG: This yellow lamp indicates that the measured resistance is lower than the reference value. When this lamp is turned ON, the buzzer sounds at the same time.

814027

- ④ Meter with two pointers--black pointer for measured value indication and red pointer for GO-NOGO reference value setting.
- ⑤ TEST: As you press this button when the instrument is set in the reset state, the test voltage which has been set by ⑩ OUTPUT VOLTAGE button is fed to ⑭ OUTPUT terminal and the instrument is set in the measuring state.
- ⑥ RESET: This button resets the instrument from the measuring state. It also resets the NG alarm if it is being generated to indicate that the test result is NG.
(OUTPUT OFF)
- ⑦ REFERENCE SET: For setting the reference value for GOOD/NG judgement. The red meter pointer indicates the reference value.
- ⑧ Mechanical zero adjustment for black pointer.
(for measured value indication)
- ⑨ Mechanical zero adjustment for red pointer.
(for reference value indication)
- ⑩ TEST VOLTAGE: Button for selecting the required test voltage.

014528

- ⑪ ⑫ Indicator lamps for test voltages.
- ⑬ OUTPUT: Button for selecting the required output mode.
- NORMAL: If the judgement is NG, the output is cut off and the NG alarm is generated. The NG alarm can be reset with ⑥ RESET button. To resume the test, press ⑤ TEST button.
- CONTINUE: Even if the judgement is NG, the output is not cut off and the measuring state is maintained. The alarm is kept generated so far as the tested object is connected and the NG judgement is being done. As you disconnect the tested object, the alarm is reset.
- ⑭ OUTPUT: Test voltage output terminal (high voltage terminal)
 (HI)
- ⑮ OUTPUT: Test voltage output terminal (low voltage terminal). Connected to current detecting circuit inside the instrument.
 (LO)

3.2 Explanation of Rear Panel

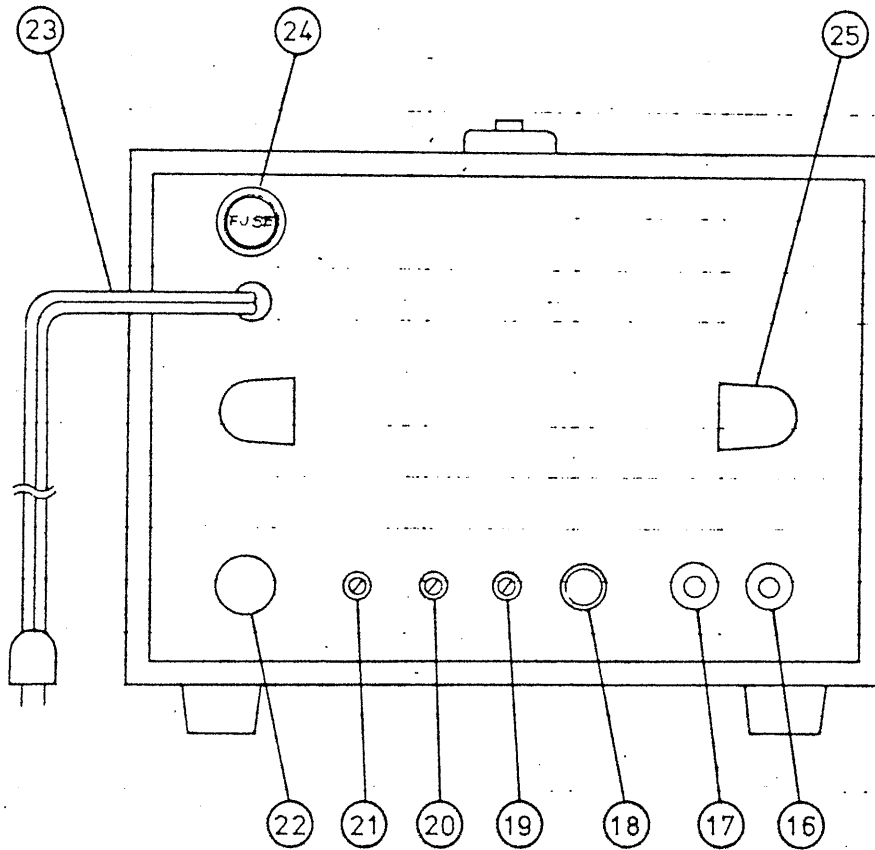

Figure 3.2

- ①⑥ ①⑦ NG: These terminals provide a "make" contact signal when judgement is NG.
- ①⑧ BUZZER: Knob for adjusting the NG alarm buzzer loudness.
- ①⑨ Ω ADJ: Semi-fixed resistor for meter "0" scale position adjustment.

- ⑳ CENTER ADJ: Semi-fixed resistor for meter calibration at scale center position.
- ㉑ ∞ adj: Semi-fixed resistor for meter adjustment at infinite scale position.
- ㉒ REMOTE: Remote control cable connector.
- ㉓ AC CORD: AC input power cord.
- ㉔ FUSE: Fuse in AC input power line. (0.5 A)
- ㉕ CORD HOOK: Bracket for taking up the cord when the instrument is not in use.

3.3 Precautions in Use

Be sure to pay due attention when handling this instrument because it generates and sends out a high voltage of 1 kV for insulation test. Although the instrument is designed with full safety features, hazards are unavoidable unless the instrument is operated cautiously. Be sure to observe the following instructions:

- (1) The connection method of the test cable of the 10 voltage line is shown in Figure 3.3. Be sure to check this cable against open-circuiting each time the instrument is used.

814631

- (2) Regarding the cable connection to the measured object, securely connect the cables starting with the IO voltage cable. Note that, if the connection is incomplete, the overall measuring circuit may become a floating state and a dangerously high voltage may build up.
- (3) When operating the instrument, be sure to wear gloves in order to protect against electric shocks.

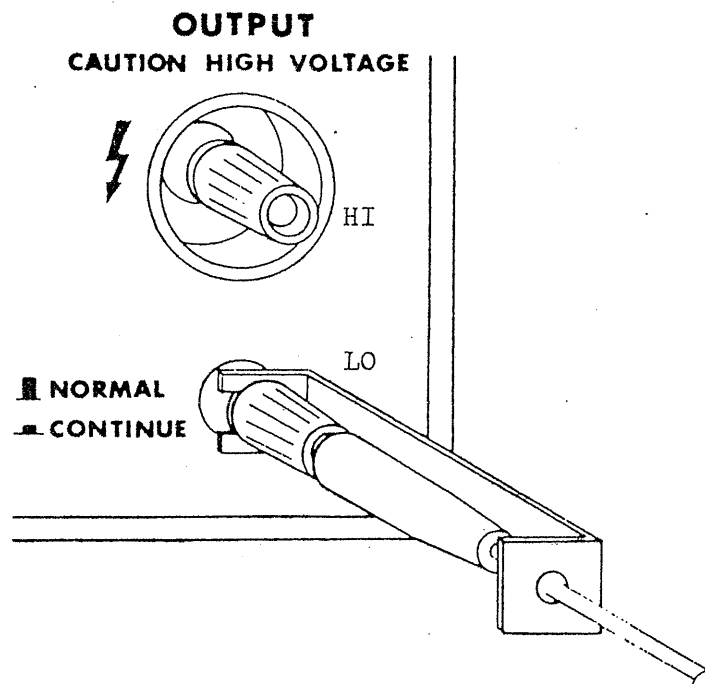

Figure 3.3

- (4) Before touching the output terminal, ensure that the TEST ON lamp has gone off.

- (5) In case of an emergency, immediately turn off the power switch and disconnect the AC power cord from the AC line outlet.
- (6) Since this instrument is an AC line operation type, measuring errors may be introduced if the measured object is connected to the AC line or to an earth ground.

In order that the instrument operates with its full performance without troubles for a long period of time, pay attention to the following:

- (1) The instrument normally operates (meeting the specifications) with an input voltage of $100\text{ V} \pm 10\%$. If the voltage is not within this range, the instrument may not operate normally and may be damaged. Be sure to make the input voltage $100\text{ V} \pm 10\%$ in an appropriate method.
- (2) Do not use or store the instrument in direct sunlight, in high ambient temperature or humidity, or in dusty atmosphere.

3.4 Test Procedure and Instrument Operation

When operating the instrument, be sure to observe the instructions of Paragraph 3.3 "Precautions in Use." The operating procedure is as follows:

814003

(A) Preparative Procedure

- (1) Before turning-on the instrument power switch, ensure that the two meter pointers are in the " ∞ " position on the scale. If they have been shifted, adjust them to the correct position. If the instrument power switch has been turned on, turn off the power switch and leave the instrument in the power-off state for approximately 5 minutes and, then, check that the pointers are in the correct position.
- (2) Turn-on the instrument power switch. The test voltage selected by (10) TEST VOLTAGE button will be indicated with (11) or (12) indicator lamp.
- (3) At the instant the power switch is turned on or off, the meter pointer may deflect irregularly. This is not an abnormal indication.
- (4) Allow approximately 10 minutes of heat-run period (warm-up period) so that the instrument operation is stabilized.
- (5) The instrument is so designed that it is not required to be adjusted for the zero and infinitive scale positions each time the instrument is used. However, when the most accurate test is required, adjust the instrument for the zero and infinity scale positions with (19) ZERO ADJ and (21) ∞ ADJ semi-fixed resistors.

214634

For the zero adjustment, keep the output terminals shorted with the IO cable and (5) TEST button set in the TEST state.

For the infinity adjustment, keep the output terminals open and ensure that no cable is connected to the HI output terminal and no tested object or any other artifact is connected to the test cable of the IO output terminal.

A standard resistor for calibration is required for adjustment of (5) CENTER ADJ semi-fixed resistor. Do not adjust the semi-fixed resistor unless the standard resistor is available.

(B) Insulation Resistance Measurement without GO-NOGO Judgement

- (1) Select the required test voltage with (10) TEST VOLTAGE button.
- (2) Move the red pointer to a position leftward than the 0 Ω scale position with (7) REFERENCE SET knob.
- (3) Make sure that (2) TEST ON lamp is not lighted, and connect the test cables to the tested object.
- (4) Press (5) TEST ON button. The black pointer will indicate the measured resistance.

- (5) Read the meter indication and press (6) RESET button.
The output will be cut off and the instrument will return to the reset state.

(c) GO-NOGO Judgement Alone

- (1) Set (13) OUTPUT button in the NORMAL (I) state.
- (2) Select the required test voltage with (10) TEST VOLTAGE button.
- (3) Observing the red pointer, set the GO-NOGO reference value with (7) REFERENCE SET knob.
- (4) Make sure that (2) TEST ON lamp is not lighted, connect the test cables to the tested object.
- (5) Press (5) TEST ON button.

When the insulation resistance of the tested object is higher than the set reference value, the black pointer indicates the measured value. As judgement is the GOOD, no alarm signal is generated. Press the RESET button so that the output is cut off and the test operation is over.

When the insulation resistance is lower than the reference value, the output is immediately cut off in order to protect the tested object. At the same time, to indicate the NG

0014636

state, the alarm lamp lights and the buzzer sounds.

Loudness of the buzzer is adjustable with (18) BUZZER knob. The alarm state can be reset by depressing (6) RESET button. As an alarm signal for an external circuit, a "make" contact signal is delivered to the binding post terminal on the instrument rear panel.

(D) GO-NOGO Judgement and Reading the Measured Value when NG

- (1) Set (13) OUTPUT button in the CONTINUE () state.
- (2) Set the required test voltage with (10) TEST VOLTAGE button.
- (3) Observing the red pointer, set the GO-NOGO reference value with (8) REFERENCE SET knob.
- (4) Make sure that (2) TEST ON lamp is not lighted, connect the test cables to the tested object.
- (5) Press (5) TEST ON button. The black pointer will indicate the measured resistance.

When the measured value is lower than the reference value set in the above paragraph (3), the alarm lamp lights and the buzzer sounds. The instrument operation in this case differs from that of the preveously explained mode of

814837

operation (OUTPUT mode is NORMAL) in that, even when the NG alarm is generated, the output is not cut off and the black pointer indicates continually the measured resistance.

- (6) Read the measured value and press (6) RESET button. The output is cut off and the NG alarm state is reset, completing one cycle of measuring operation.
- (7) If you disconnect the tested object with the output being delivered instead of pressing (6) RESET button in the above paragraph (6), the NG alarm state will be reset. However, do not touch the output terminals or test cables while the output is being delivered in order to avoid electric shock hazards.
- (8) If the insulation resistance is larger than the reference value, the instrument operation remains the same irrespective of whether (13) OUTPUT mode selector switch is set in the NORMAL state or the CONTINUE state.

4. CALIBRATION

An internal voltage of this instrument is as high as 1.5 kV and moreover the instrument circuits are a floating type. Never try to service the internal circuits by yourself--contact our representative in your area when service for the internal circuits is required. This section explains instrument calibration (meter indication) with external controls (semi-fixed resistors on the instrument rear panel).

Preparative Procedure

- (1) The instrument has two rated voltages of 500 V and 1000 V. For calibration, use the one at which the instrument is operated more frequently. When the instrument is calibrated at one voltage, it satisfies the performance specifications without adjustment for the other voltage.
- (2) Prepare a standard resistor of $100\text{ M}\Omega \pm 1\%$, withstanding voltage 1000 V (or 500 V).
- (3) Perform mechanical zero adjustment of the indicating meter as explained in Paragraph 3.4 "Test Procedure and Instrument Operation."
- (4) Turn-on the instrument power and allow more than 15 minutes of heat-run period for operation stabilization.

Calibration

- (1) Connect the 100 M Ω standard resistor to the OUTPUT terminals and press the TEST button. So adjust the CENTER ADJ semi-fixed resistor that the black pointer indicates precisely the 100 M Ω scale position. After the adjustment is over, press the RESET button to cut off the output.
- (2) Short the OUTPUT terminals and press the TEST button. So adjust the ZERO ADJ semi-fixed resistor that the black pointer indicates precisely the "0" scale position. After the adjustment is over, press the RESET button to cut off the output.
- (3) Repeat the adjustments of (1) and (2) alternately for twice or thereabout.
- (4) Open the output terminals and so adjust the ∞ ADJ semi-fixed resistor that the black pointer indicates precisely the infinitive scale position.
- (5) Repeat the adjustments of (1) and (4) alternately for twice or thereabout.
- (6) Finally, adjust in the order of (1), (2) and (4).

014640

5. OPTIONS

5.1 Model 929-100M Standard Resistor for Calibration

- o Used for calibration at approximately scale center.
- o Can be readily attached to the output terminals of the instrument.
- o Standard resistance is 100 M Ω .

Specifications

Nominal resistance:	100 M Ω
Resistance accuracy:	1% (at 25°C +10°C (77°F +18°F))
Temperature coefficient:	100 PPM/°C or less
Voltage coefficient:	1 PPM/V or less
Withstanding voltage:	1.2 kV

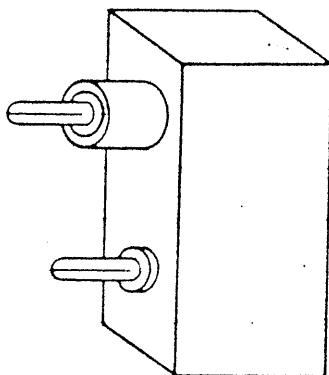

Configuration of the Standard Resistor

5.2 Model 913A Remote Control Box

- o Capable of the TEST and RESET operations.

Specifications

Functions:

OPERATE switch: The TEST button is effective only when this switch is set in the ON position.

TEST button: As you press this button, the instrument is set in the measuring state from the reset state.

RESET button: This button is for cutting off the output or resetting the NG alarm state.

Case dimensions: 150 W × 70 H × 40 D mm
(5.91W × 2.76H × 1.57D in.)

Extension cable: With 5-pin DIN connector, approximately 1.5 meters (4.9 ft.) long.

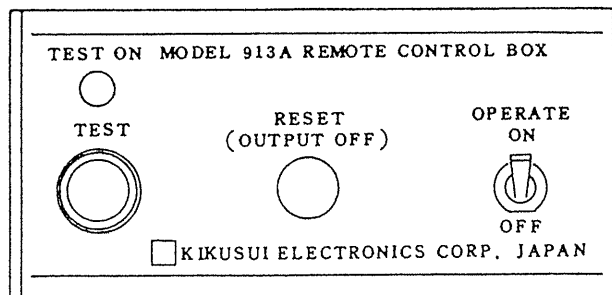

Front panel of the Remote Control Box

314942

Operation Method and Notes

- o Connect the extension cable of the remote control box to the DIN connector on the rear panel of the instrument.
- o When the extension cable is connected, the TEST button on the front panel of the instrument becomes ineffective and the test operation can be controlled from the remote control box alone. The reset operation is controllable from both instrument front panel and remote control box.
- o Except when the test is being performed, keep the OPERATE switch of the remote control box in the OFF position.